

Name: _____

Date: _____

1. The garden below was divided into two regions—one for carrots and one for peas.

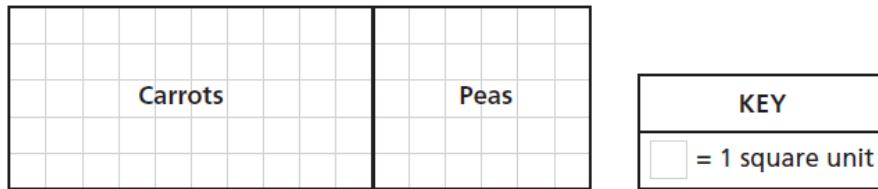

Which expression represents the area, in square units, of the whole garden?

- A. $(5 + 10) + (5 + 6)$
- B. $(5 \times 10) \times (5 \times 6)$
- C. $(5 \times 10) + (5 \times 6)$
- D. $(5 + 10) \times (5 + 6)$

2. Label the side lengths of the shaded and unshaded rectangles when needed. Then, find the total area of the large rectangle by adding the areas of the two smaller rectangles.

a.

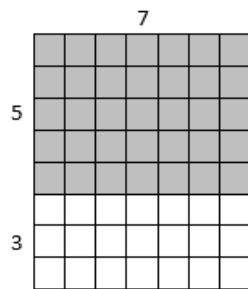

$$\begin{aligned}
 8 \times 7 &= (5 + 3) \times 7 \\
 &= (5 \times 7) + (3 \times 7) \\
 &= \underline{\quad} + \underline{\quad} \\
 &= \underline{\quad} \\
 \text{Area: } &\underline{\quad} \text{ square units}
 \end{aligned}$$

b.

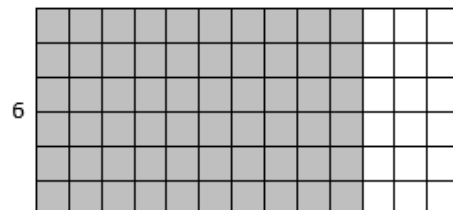

$$\begin{aligned}
 6 \times 13 &= 6 \times (\underline{\quad} + 3) \\
 &= (6 \times \underline{\quad}) + (6 \times 3) \\
 &= \underline{\quad} + \underline{\quad} \\
 &= \underline{\quad} \\
 \text{Area: } &\underline{\quad} \text{ square units}
 \end{aligned}$$

3. Which expressions can be used to find the total area, in square centimeters, of these two rectangles?

Select the **two** expressions that represent the total area.

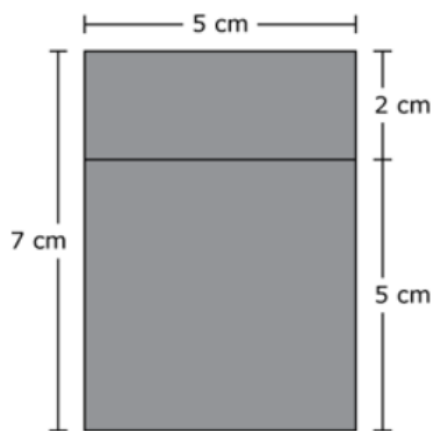

- A. $5 + 7$
- B. 5×7
- C. 5×5
- D. 7×7
- E. $(5 \times 2) + (5 \times 5)$
- F. $(5 \times 2) + (2 \times 2)$

4. Write 3 different expressions that could be used to find the area of each rectangle below. Then, use one of your expressions to find the area.

a.

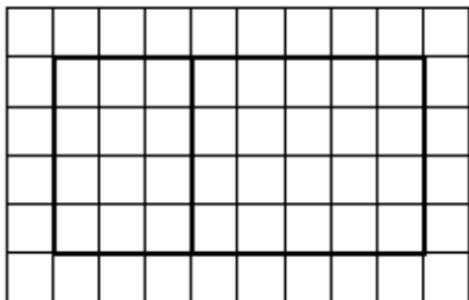

Area:

b.

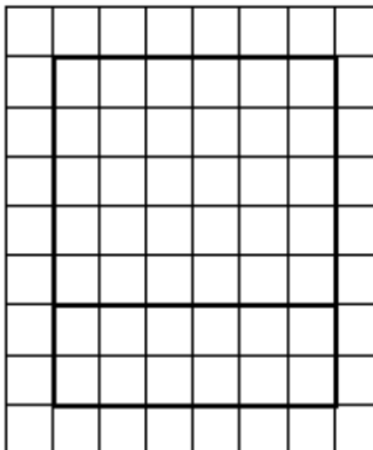

Area:

5. Draw the rectangle that matches each expression in the grids underneath. Then find the area of the rectangle.

a. $(2 \times 8) + (3 \times 8)$

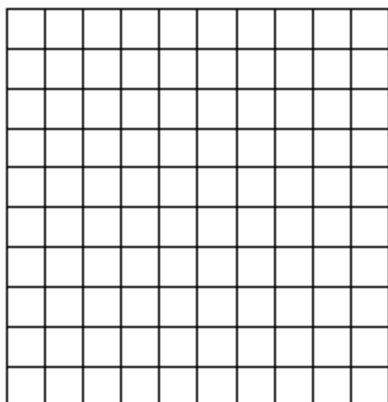

b. $(5 + 2) \times 4$

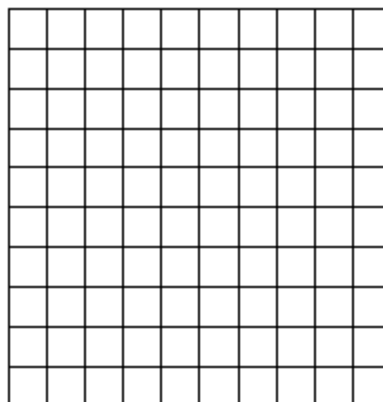

6. The grid below shows table C and table D placed end to end to make a new, larger tabletop.

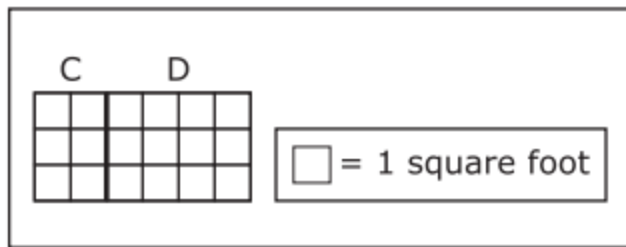

Tori uses the expression $3 \times (2 + 4)$ to find the total area of the new, larger tabletop.

Leo uses the expression $(3 \times 2) + (3 \times 4)$ to find the total area of the new, larger tabletop.

- Find the total area, in square feet, of the new, larger tabletop.
- Use the grid to explain why both Tori's expression and Leo's expression are correct.

7. Mr. Nuccio's sandwich shop was 9 yards long as 7 yards wide before he added a new section. The shaded squares below represent the new section.

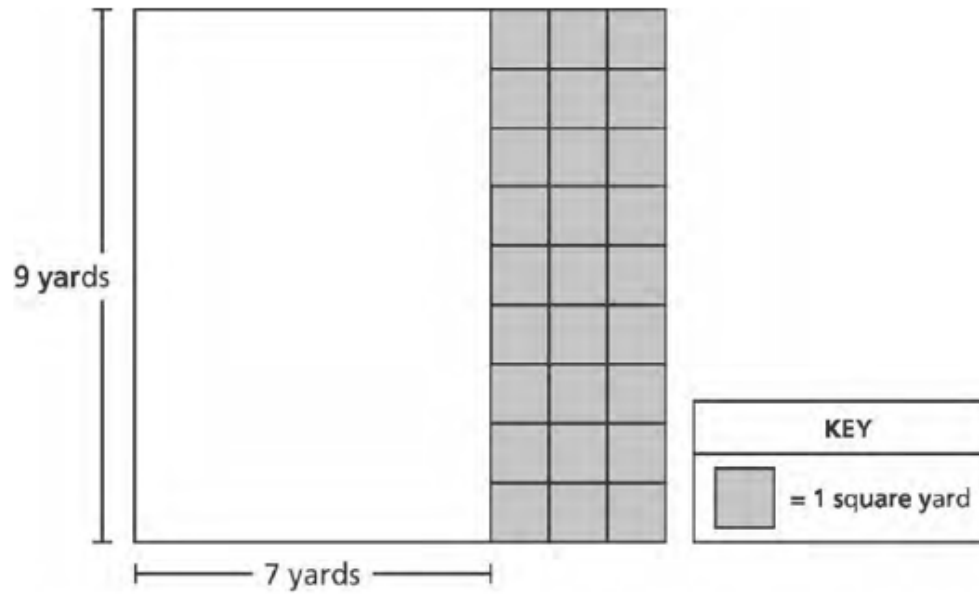

What is the total area, in square yards, of Mr. Nuccio's sandwich shop after the new section was added?

Sources

1. EngageNY [New York State Testing Program Grade 3 Common Core Mathematics Test Released Questions with Annotations August 2013](#)
— #124030045_3
From [EngageNY.org](#) of the New York State Education Department. [New York State Testing Program Grade 3 Common Core Mathematics Test Released Questions with Annotations August 2013](#). Internet. Available from <https://www.nysed.gov/curriculum-instruction/engageNY>; accessed Sept. 25, 2018, 4:39 p.m..
2. EngageNY Mathematics [Grade 3 Mathematics > Module 4 > Topic C > Lesson 10](#) — Problem Set, Question #1 [Grade 3 Mathematics > Module 4 > Topic C > Lesson 10](#) of the New York State Common Core Mathematics Curriculum from [EngageNY](#) and [Great Minds](#). © 2015 Great Minds. Licensed by EngageNY of the New York State Education Department under the [CC BY-NC-SA 3.0 US](#) license. Accessed Dec. 2, 2016, 5:15 p.m.. Modified by Fishtank Learning, Inc.
3. MCAS Digital Item Library [Item MA623068649](#)
[Item MA623068649](#) from the [MCAS Digital Item Library](#) is made available by the [Massachusetts Department of Elementary and Secondary Education](#). © 2018 Pearson 2018. Accessed Jan. 7, 2019, 1:28 p.m..
4. Achievement First [Grade 3, Unit 7, Lesson 8 \(2018-2019\)](#) — Independent Practice, Question #1 [Grade 3, Unit 7, Lesson 8 \(2018-2019\)](#) is made available by [Achievement First](#) as a part of their [Open Source web portal](#) under a [CC BY 4.0](#) license. Copyright © 1999-2017 Achievement First. Accessed Jan. 2, 2019, 3:23 p.m.. Modified by Fishtank Learning, Inc.
5. Achievement First [Grade 3, Unit 7, Lesson 8 \(2018-2019\)](#) — Workshop, Question #3 [Grade 3, Unit 7, Lesson 8 \(2018-2019\)](#) is made available by [Achievement First](#) as a part of their [Open Source web portal](#) under a [CC BY 4.0](#) license. Copyright © 1999-2017 Achievement First. Accessed Jan. 2, 2019, 3:23 p.m.. Modified by Fishtank Learning, Inc.
6. PARCC Mathematics Practice Tests [Grade 3 Paper-Based Practice Test](#) — Question #36 Part B [Grade 3 Paper-Based Practice Test](#) from [Mathematics Practice Tests](#) is made available by [Partnership for Assessment of Readiness for College and Careers](#). © Copyright 1998 - 2015 Pearson Education, Inc. or its affiliate(s). All rights reserved. Accessed Sept. 25, 2018, 4:26 p.m..
7. EngageNY [New York State Testing Program Grade 3 Common Core Mathematics Test Released Questions May 2016](#) — Question #49
From [EngageNY.org](#) of the New York State Education Department. [New York State Testing Program Grade 3 Common Core Mathematics Test Released Questions May 2016](#). Internet. Available from <https://www.nysed.gov/curriculum-instruction/engageNY>; accessed Oct. 12, 2018, 1:17 p.m.. Modified by Fishtank Learning, Inc.